

COMBO CAMA + MESA DE NOCHE

M01680MX-GSWE

M01680MX-MZBL

Revisión:00/30/07/2021

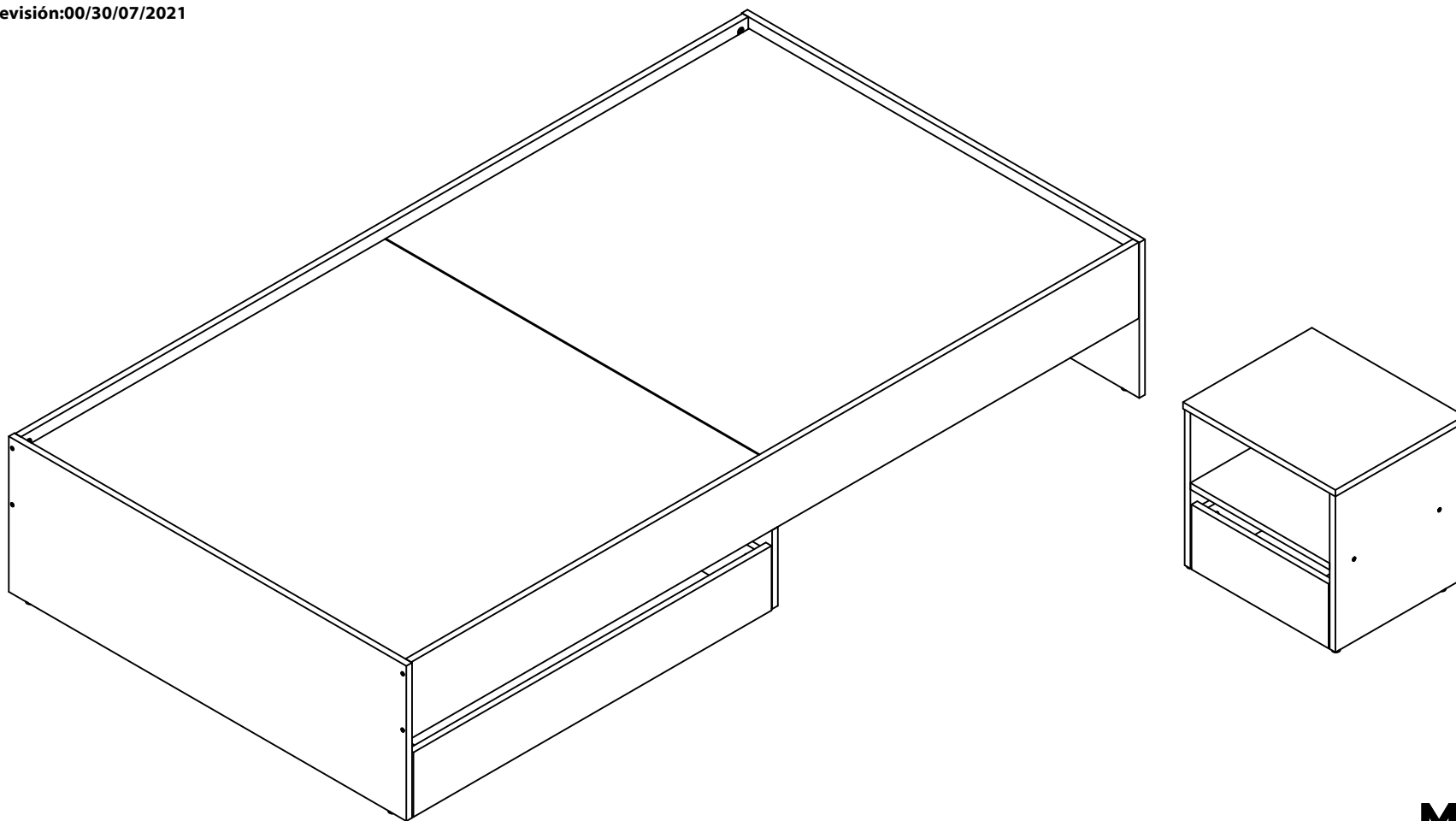

Maderkit
Muebles que innovan tu hogar

+57 311 340 2222

maderkit.com.co

/Maderkit S.A







/Maderkit S.A

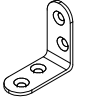

018000 - 180 - 425

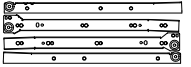
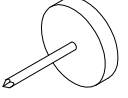
SERVICIO AL CLIENTE LINEA GRATUITA A NIVEL NACIONAL

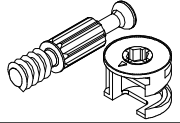
*Los accesorios mencionados en el instructivo de armado podrían variar sin previo aviso.

ACCESORIOS

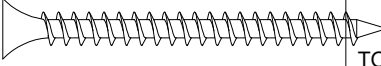
DIBUJO	NOMBRE	CANT.	ITEMS
	CANTONERA 3 CND3818	4	0004644
	CORREDERA METALICA FULL EXTEN 550MM MED	1	013783
	CORREDERA METALICA NEGRA 300MM	1	20080038
	DESLIZADOR PUNTILLA	10	BL 007391 CF 20080011
	MANGO M6X11 EXT PLASTICO	14	0004641
	PERNO CONECTOR MINIFIX 15MM	8	0002715
	PUNTILLA DE ACERO 3/4	11	20020006
	TARUGO 8X30	18	20030001

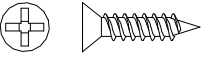
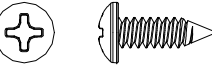
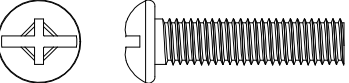
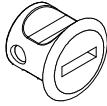
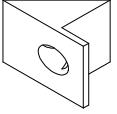
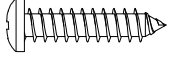
DIBUJO	NOMBRE	CANT.	ITEMS
	TORNILLO 6*2 AVE PHI AUTOPERFORANTE	15	0000152
	TORNILLO 6X3 AVE PHI AUTOPERFORANTE	8	0004707
	TORNILLO 6X5/8 AVE PHI ZINC AGLOMERADO	17	0004705
	TORNILLO 8*1/2 PAN PHI ZINC	24	0004672
	TORNILLO M6X25 PAN PHI ZINC	14	0004650
	TUERCA NUMERO 2	8	BL 0004674 NE 0004633
	SOPORTE PLASTICO PARA FONDO	4	0004976
	TORNILLO 6X3/4 PAN PHI ZINC	4	0004488

La información y características de accesorios que aparecen en este MANUAL DE INSTRUCCIONES pueden estar sujetas a cambios dependiendo de su efectiva disponibilidad y podrán variar de acuerdo con la versión comercializada. MADERKIT S.A., se reserva el derecho de realizar modificaciones en cualquier momento y sin previo aviso. Esta información está basada en la última actualización entregada por el fabricante, y las características definitivas del mueble serán las que conozca y acepte el comprador. Vigencia hasta una nueva actualización de la fábrica. Las piezas y/o accesorios que deban reponerse por efectos de garantía se harán por la versión equivalente disponible en el momento del elemento a reponer.

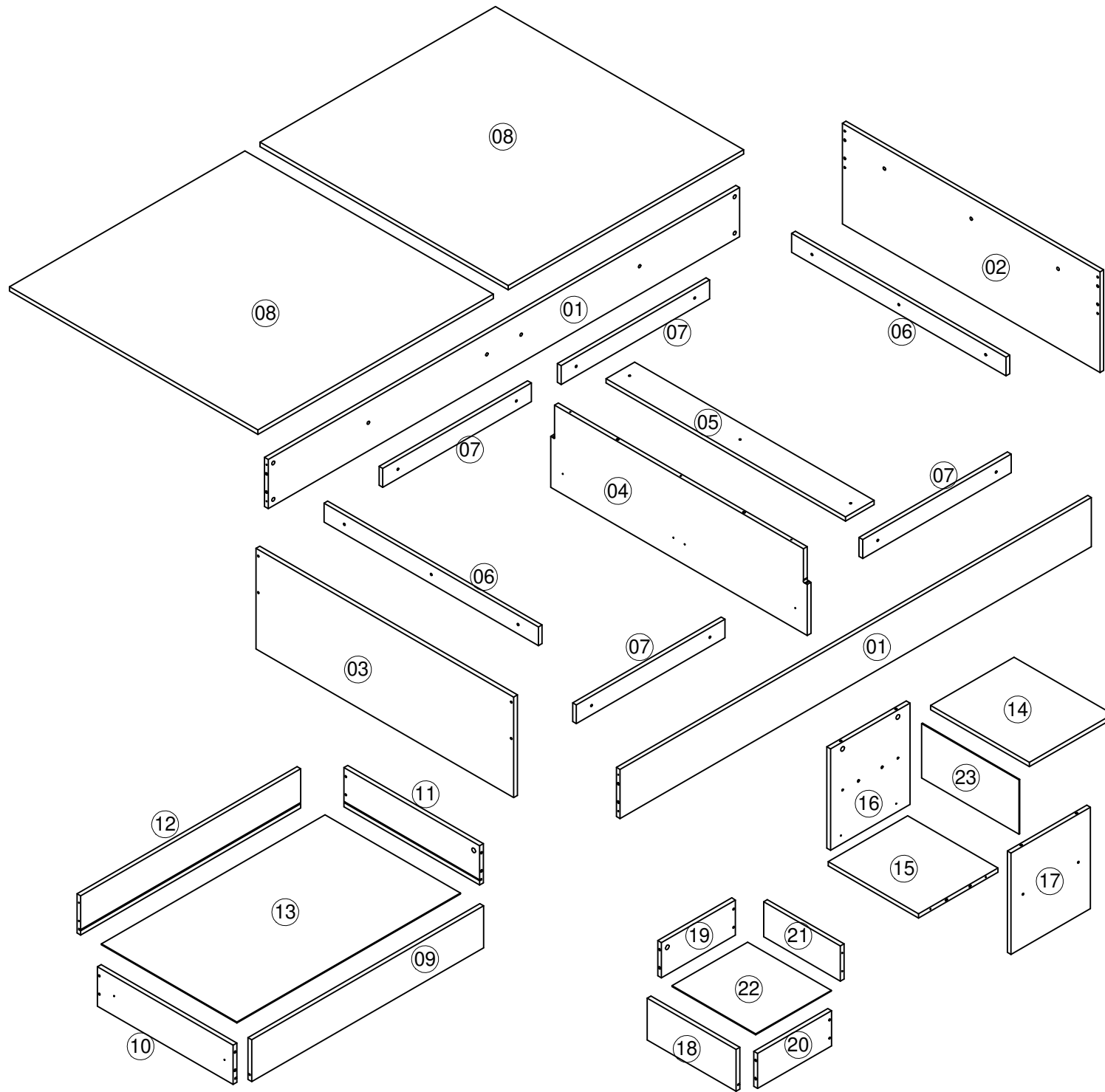

PASO 2

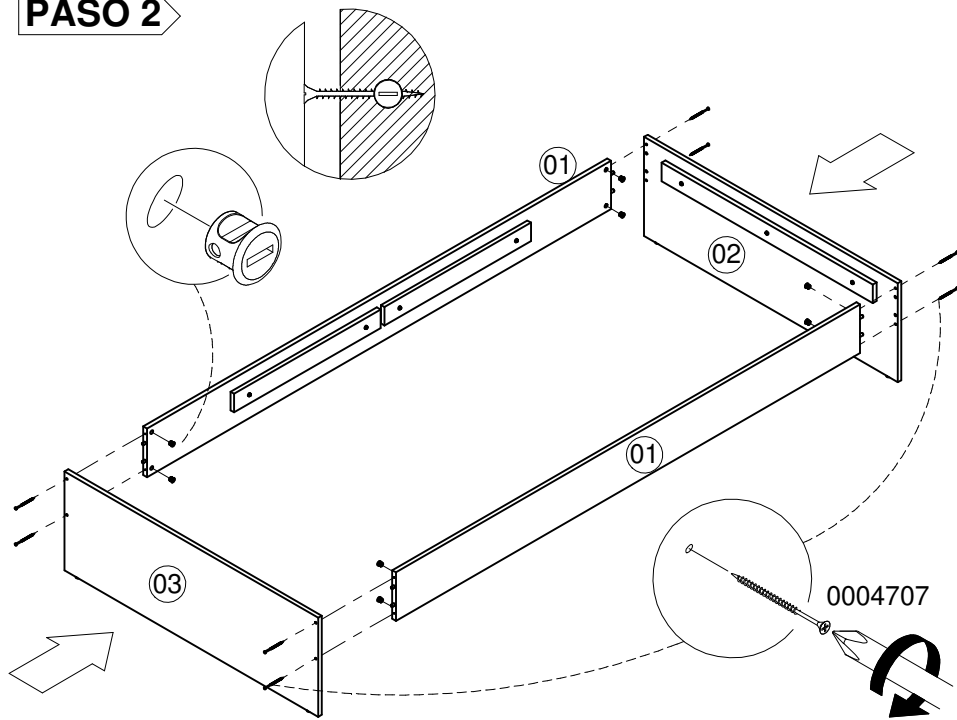

PASO 4

Instalar la cantonera a los cuatro extremos de la pieza #04 y unir con las piezas # 07

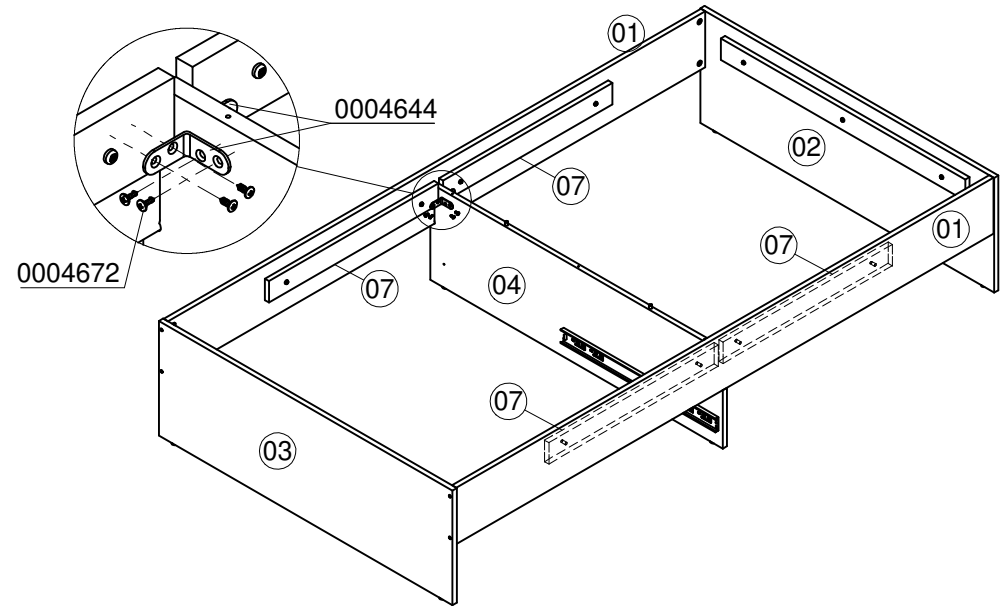

PASO 3

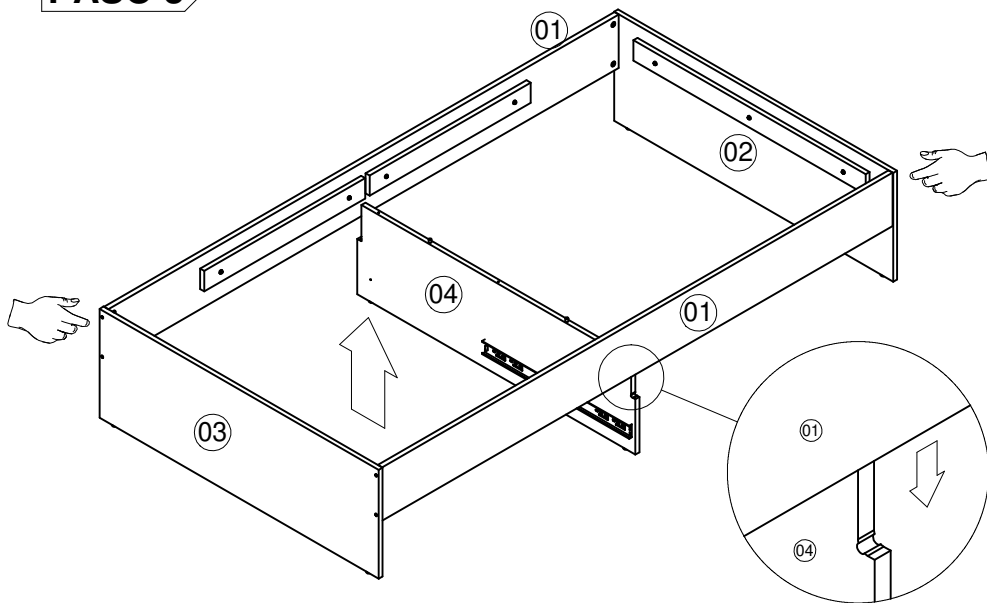

PASO 5

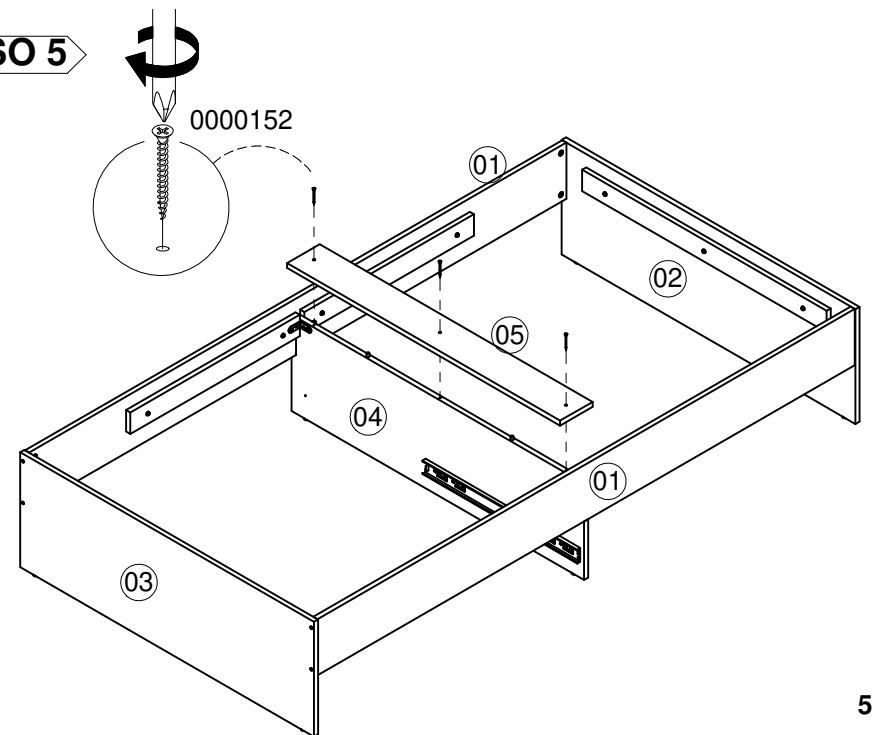

PASO 6

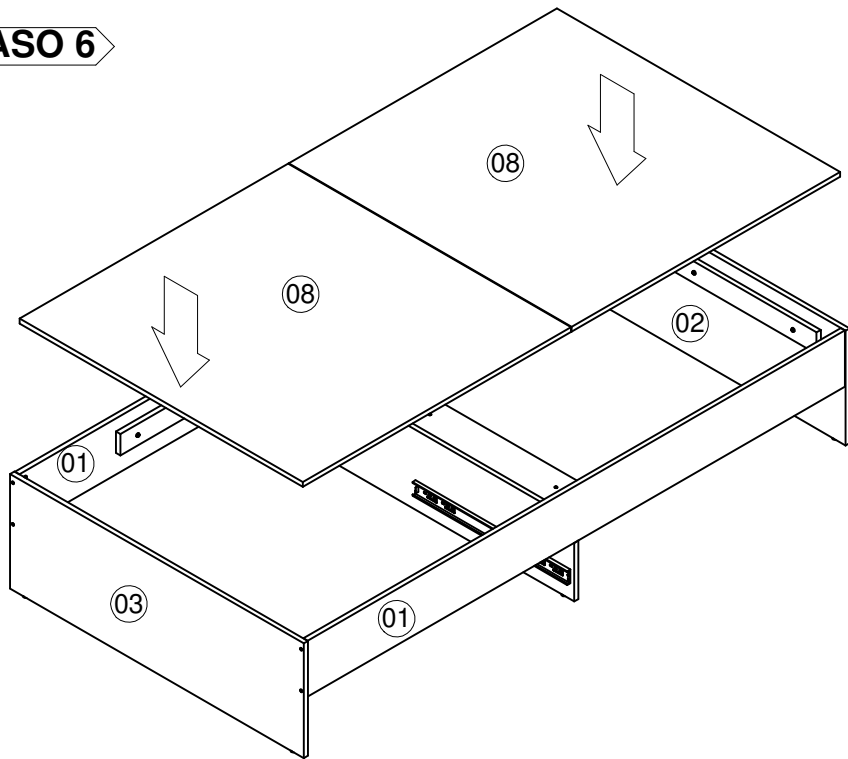

PASO 7

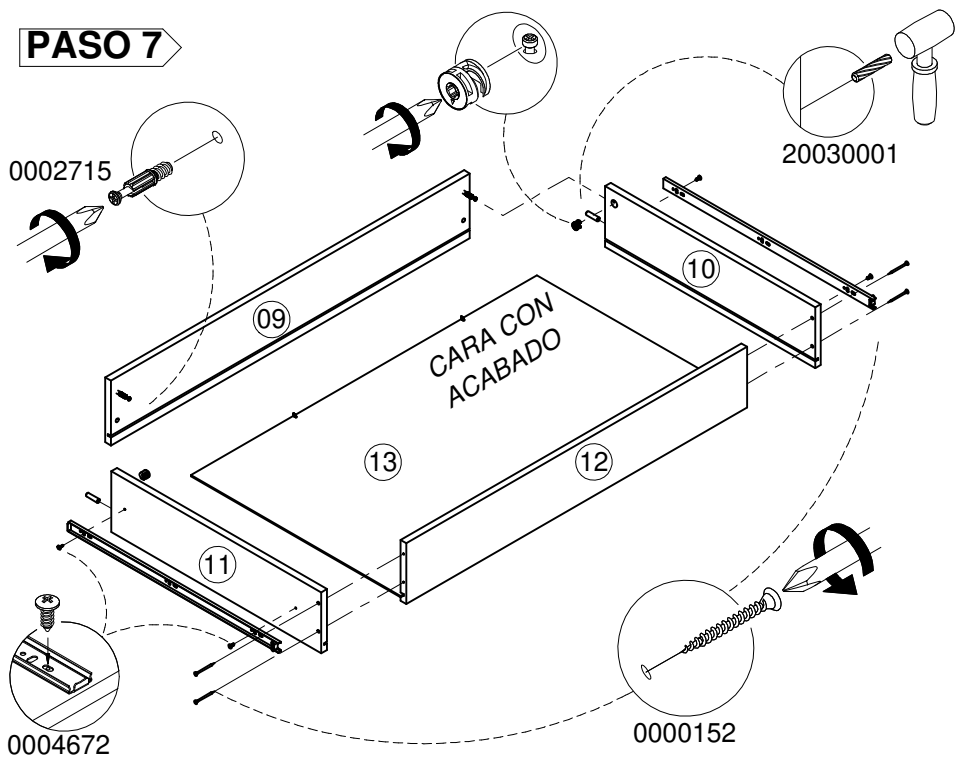

PASO 8

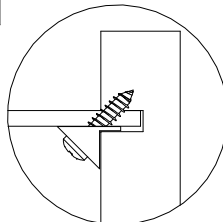
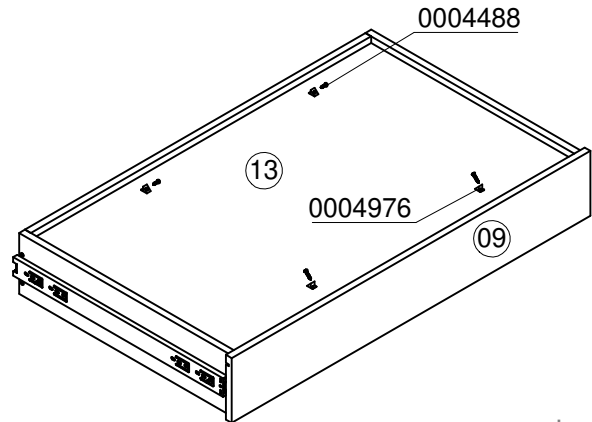

Insertar en la ranura

PASO 9

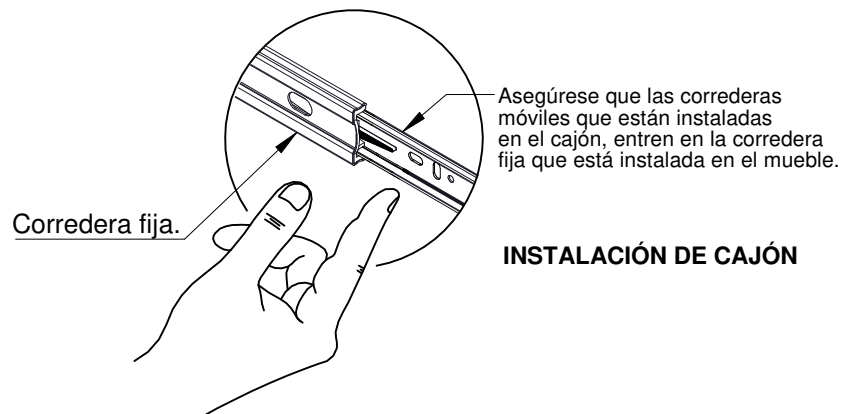
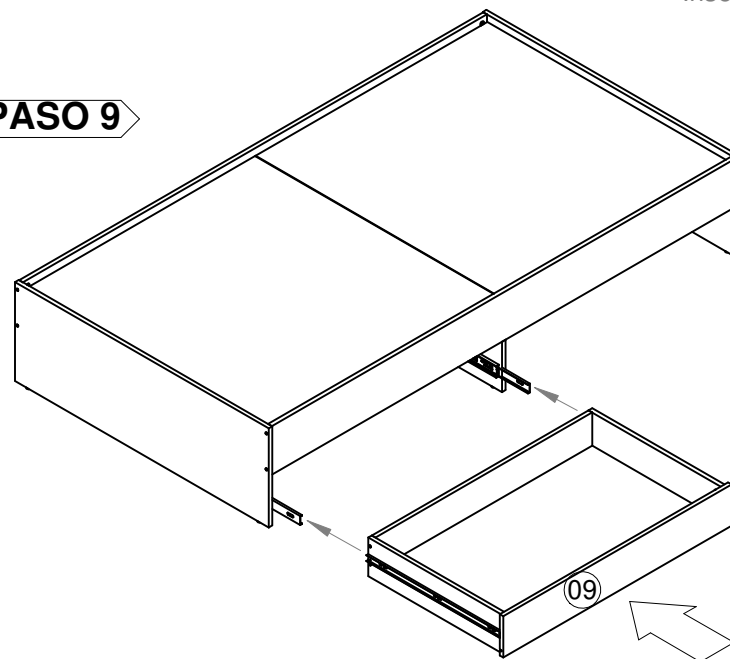

INSTALACIÓN DE CAJÓN

PASO 10

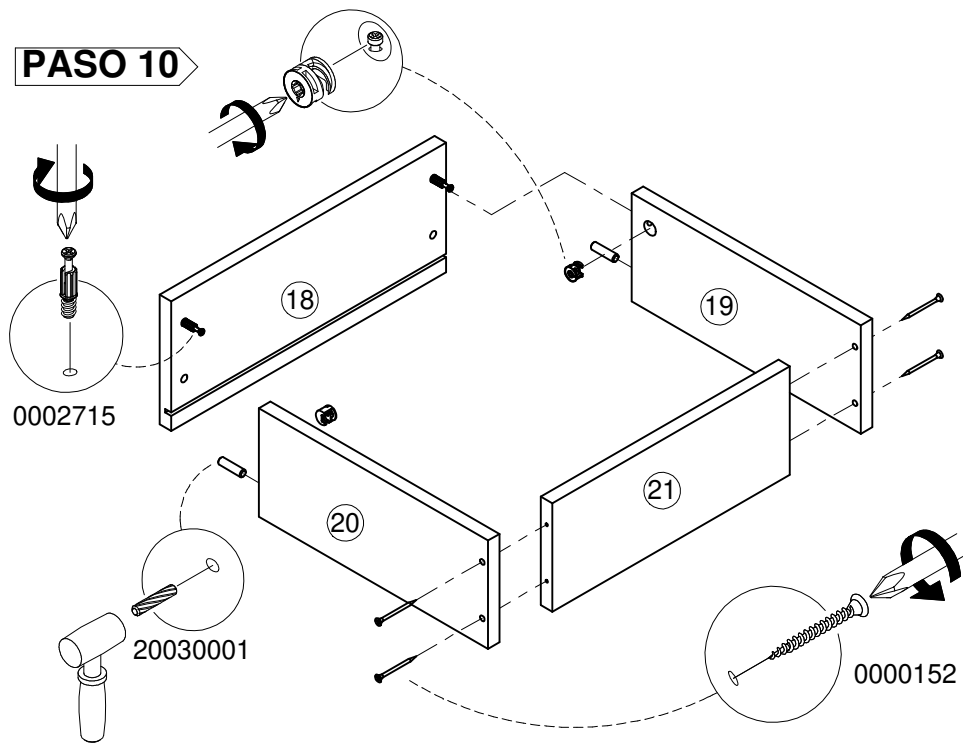

PASO 12

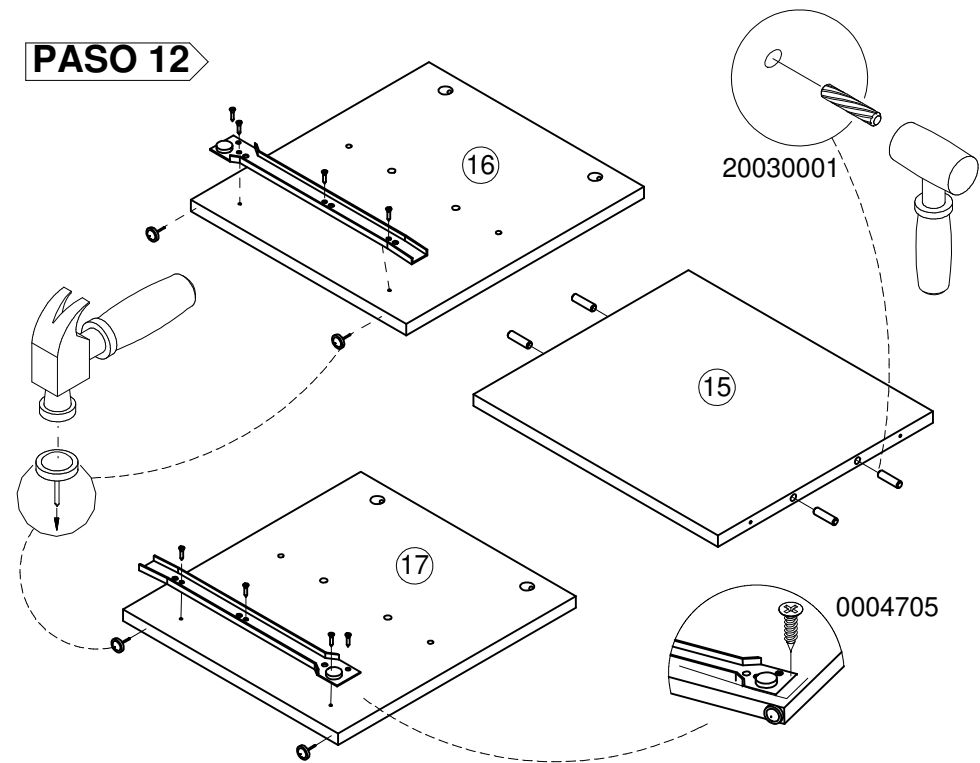

PASO 11

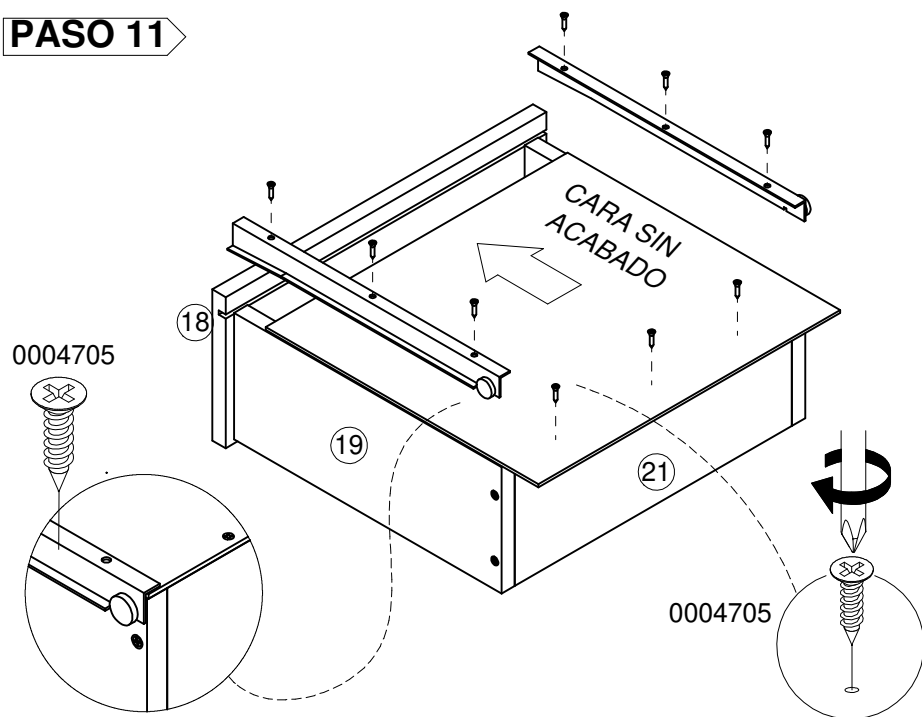

PASO 13

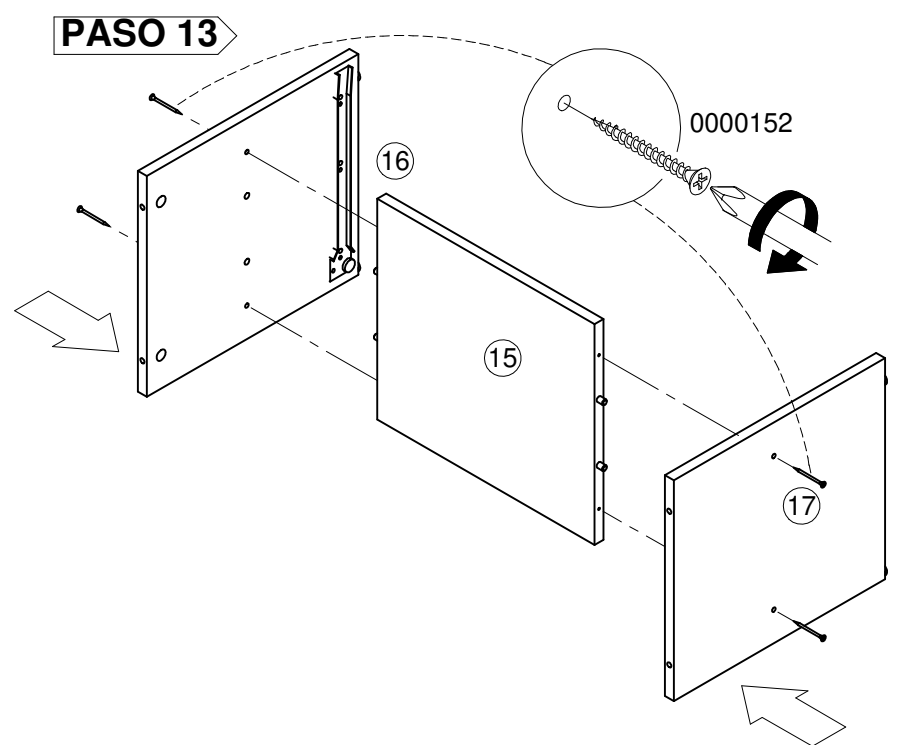

PASO 14

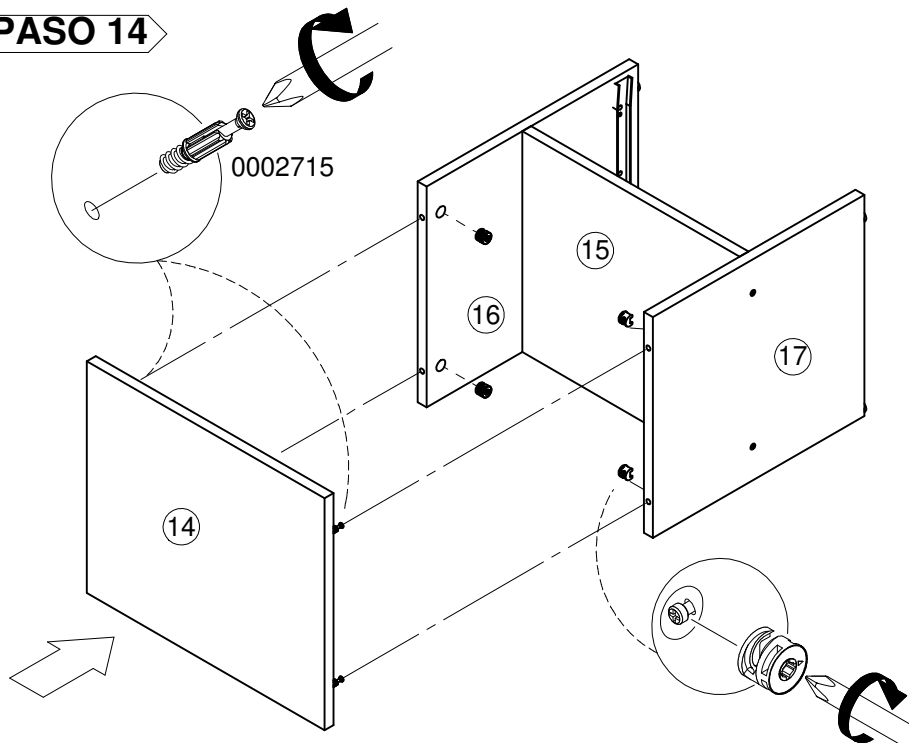

PASO 16

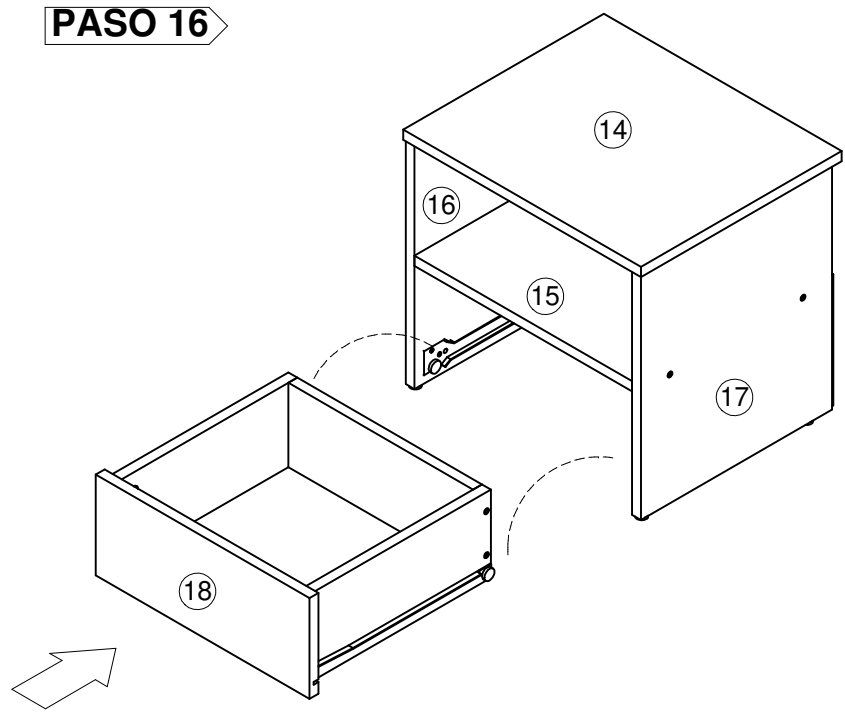

PASO 15

